

marmox multiboard

Waterproofing • Insulating • Drylining

Tile it • Plaster it • Render it



Product & Installation Guide

Contents

Plaster it - Tile it - Render it	4
Technical Info, Sizes & Quality Assurance?	6
Multiboard on Walls	
Screws & washers - Timber frame.....	8
Screws & washers - Solid walls.....	9
Full bed of adhesive - Solid walls.....	10
Dot, dab & dowel - Solid walls.....	11
Multiboard on Floors	
Full bed of adhesive.....	12
Screws & washers - Sheet wood flooring.....	13
Sound Multiboards	14
Sloping Multiboards	16
Construction - Thicker Multiboards	18
Curved Multiboards	20
Pipe Boxing Multiboards	22
Multiboard Niches	24
Multiboard Basins	26
Multiboard Bath Panel Kits	28
Marmox Showerlay - Point Drain	30
Marmox Showerlay - Linear Drain	32
Accessories	34
Other Marmox Products	35



Tile it • Plaster it • Render it



Tiles - Ultimate substrate for tiles. Hold up to 100kg/m²



Plaster - No need to PVA, plaster directly onto them



Render - Will support many different types of render

Marmox Multiboard: The tried and trusted construction material which merges water proofing, insulation and structural strength into a reliable, BBA certified board. Lightweight and easy to cut with minimal dust, it accommodates tiling, plastering, and rendering, both indoors and outdoors.

Why use Marmox Multiboard?



FULLY WATERPROOF

Fully waterproof means that no water at all can be absorbed into the core and Multiboard won't warp or degrade in wet areas.



HIGH INSULATION

Marmox Multiboards (10mm and thicker) are CE-marked, rigid, insulation boards with thermal conductivities between 0.033 to 0.036W/mK.



TILE, PLASTER OR RENDER

As well as having multiple properties, Marmox Multiboard can be covered with multiple different finishes. BBA certified to accept tiles, plaster or render.



LIGHTWEIGHT & EASY TO CUT

Significantly lighter than most alternative boards, such as cement-based or plasterboard, allowing for easy installation. Easy and clean to cut.

What is it made from?

Extruded polystyrene foam (XPS) which is reinforced with a fibreglass mesh and then embedded in a cement polymer mortar, covering both sides.

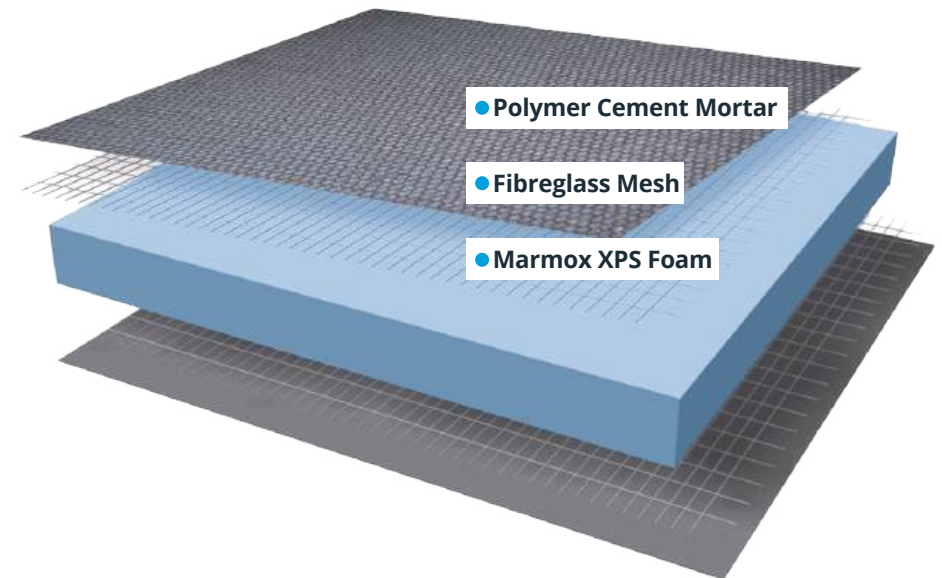

LOADING CAPACITY EXCEEDS 100kg/m²

Marmox Multiboards fixed to a masonry wall with a continuous bed of tile adhesive can achieve loading capacity exceeding 100kg/m².



NO TANKING MEMBRANE REQUIRED

The XPS core of Multiboard is entirely waterproof and requires no additional tanking membrane in wet areas. All joints should be sealed with Marmox S/A Waterproof Tape.



EFFECTIVE DECOUPLING

The combination of the rigid outer shell and the XPS core, which absorbs lateral movement, makes Multiboard an effective decoupling layer.



MARMOX LIFETIME GUARANTEE

Marmox product range comes with a Lifetime Guarantee for total peace of mind.



Specification

Sizes & Weights					
Description	Size (mm)			Weight (kg)	R Value (m ² k/w)
	Thickness	Width	Length		
Multiboard Short	4	600	1200	2.20	0.11
	6			2.30	0.17
	10			2.59	0.28
	12.5			2.68	0.35
	20			2.97	0.56
	30			3.26	0.83
	40			3.84	1.11
	50			4.03	1.39
	60			4.32	1.67
Multiboard Long	10	2400	2400	5.18	0.28
	12.5			5.37	0.35
	20			5.95	0.56
	30			6.52	0.83
	40			7.68	1.11
	50			8.06	1.39
	60			8.64	1.67
Multiboard Big	12.5	1200	2400	11.00	0.35
	20			12.00	0.56

Quality Assurance



Technical Data		
Compressive Strength (at 10% deformation)	(EN 826)	300kPa (30 tonnes/m ²)
Thermal Conductivity	(EN 13164)	0.034 Watts/mK
Water Absorption of XPS	(EN 12087)	<0.7%
Coefficient of Thermal Expansion	(ASTM D696)	8 x 10 ⁻⁶ k ⁻¹
Flammability	(EN 13501)	Class E
ODP		zero
GWP		0.29
Maximum Tile Loading Weight	CMB 02/16	To the limit of the tile adhesive (typically 100kg/m ²)
Declaration of Performance		EN13164

Conversion to Square Metres (sqm)						
Thickness	Short Multiboards				Long Multiboards	
	Carton		Pallet		Pallet	
	Quantity	Sqm	Quantity	Sqm	Quantity	Sqm
4	10	7.20	300	216.00	-	-
6	8	5.76	240	172.80	-	-
10	6	4.32	150	108.00	150	216.00
12.5	6	4.32	120	86.40	120	172.80
20	5	3.60	80	57.60	80	115.20
30	4	2.88	60	43.20	60	86.40
40	3	2.16	45	32.40	45	64.80
50	2	1.44	36	25.92	36	51.84
60	2	1.44	30	21.60	30	43.20

Note: Big Boards are available in pallets of 40.

Timber/Metal
Screws & washers

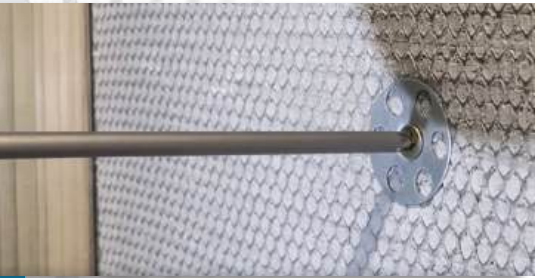

Solid Wall
Screws & washers



Key Benefits

- Fully waterproof
- High insulation
- Holds up to 100kg/m²
- Tile or plaster

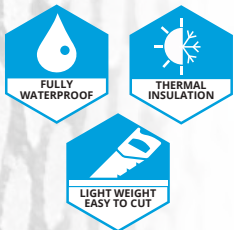

Fitting Instructions

1. Measure the Multiboard and cut to size with a saw or knife.
2. 10 & 12.5mm Multiboards - Studwork set at 300mm centres. 3 rows of 5 fixings for short boards.
3. 20mm and thicker - Studwork set at 600mm centres. 5 fixings down each long side for short boards
4. Tape joints with Marmox Reinforcing tape.
5. In wet areas use Marmox S/A Waterproof Tape.
6. You can then tile, plaster or render.



Fitting Instructions

1. Measure the Multiboard and cut to size with a saw/knife.
2. Offer the Multiboard up to the wall and use Marmox washers and and suitable screws. Screws should generally be at least 20mm longer than the thickness of the board. Be aware of any electrical wires or pipe work that may be in the wall.
3. Fixings 1-2cm from the edges...
 Short boards (4-6mm) – 3 rows of 5 fixings
 Short boards (10-60mm) – 3 rows of 3 fixings
 Long boards – 3 rows of 5 fixings
4. Tape all the joints with Marmox Reinforcing Tape.
5. In wet areas use Marmox S/A Waterproof Tape.
6. You can then tile, plaster or render.

Note

- *Marmox washers are available in metal or plastic, in bags of 100. Marmox metal washers are also available in tubs of 500.*



Marmox Washers

Solid Walls
Full bed of tile adhesive



Key Benefits

- Fully waterproof
- High insulation
- Holds up to 100kg/m²
- Tile or plaster

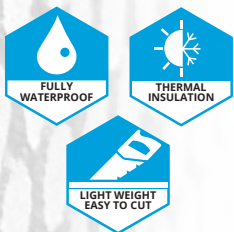

Fitting Instructions

1. Make sure the wall has been dusted down and is free from any protrusions.
2. Any thickness can be used on walls.
3. Comb a powder based flexible adhesive over the whole surface of the Multiboard or the wall itself (6/8mm trowel)
4. Push firmly onto the wall. It's ideal to stagger the joints.
5. Be sure to tape all the joints with Marmox Reinforcing Tape.
6. In wet areas use Marmox S/A Waterproof Tape.
7. You can then tile, plaster or render.



Solid Wall
Dot, dab & dowels



Fitting Instructions

1. Measure the Multiboard and cut to size with a saw or knife.
2. Drill fixing holes through the Multiboard into the solid wall.
 Short boards - 5 fixings (1 in each corner, 1 in the middle)
 Long boards - 8 fixings (6 around edges, 2 in the middle)
3. Put a dab of powder based flexible tile adhesive over the holes on the Multiboard and offer up to the wall.
4. Push firmly into place and then level with a spirit level.
5. Push in the white dowel and then hammer in the red pin.
6. Tape all the joints with Marmox Reinforcing Tape.
7. In wet areas use Marmox S/A Waterproof Tape.
8. You can then tile, plaster or render.

Note

- 12.5mm Multiboard (or thicker) should be used on walls with this method.
- Dowel fixings are only for use with concrete blocks (not for use with aircrete, AAC or thermal blocks).



Marmox
Fixing
Dowels

Floors
Full bed of tile adhesive

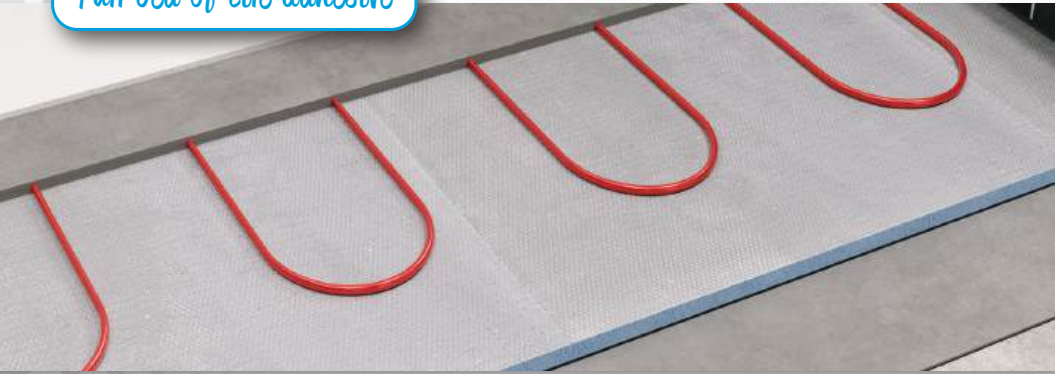

Key Benefits

- Fully waterproof
- High insulation
- Load bearing
- Works with underfloor heating

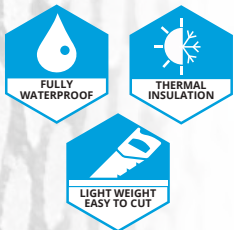

Fitting Instructions

1. Ensure floor is dust free and level. Secure all floor boards.
2. Using a 6/8mm trowel (20mm trowel for uneven floors), comb a full bed of powder based flexible adhesive over the surface of the Multiboard or onto the floor.
3. Push firmly onto the floor, being sure to stagger the joints.
4. Tape joints with Marmox Reinforcing Tape.
5. Use Marmox S/A Waterproof tape to waterproof joints.
6. Tile directly onto the Multiboard. On floors, tiles should be at least 50mm x 50mm.
7. Electric Underfloor Heating – Lay cable directly onto the Multiboard, encase with levelling compound and then tile.

Floors
Screws & washers



Fitting Instructions

1. Secure down any loose sheet flooring.
2. Use a screw and Marmox washer at every 300mm, making sure the screws embed into the floor by at least 20mm.
3. Short boards - 3 rows of 4 fixings (1 inch from the edges)
4. Tape all the joints with Marmox Reinforcing Tape.
5. In wet areas use Marmox S/A Waterproof Tape.
6. Tile directly onto the Multiboard. On floors, tiles should be at least 50mm x 50mm.
7. Electric Underfloor Heating – Lay cable directly onto the Multiboard, encase with levelling compound and then tile.

Note

- For traditional floors, use a minimum of a 10mm Marmox Multiboard
- Do not screw fix to traditional floor boards



Marmox Washers

Absorb Sound
Under tiled floors

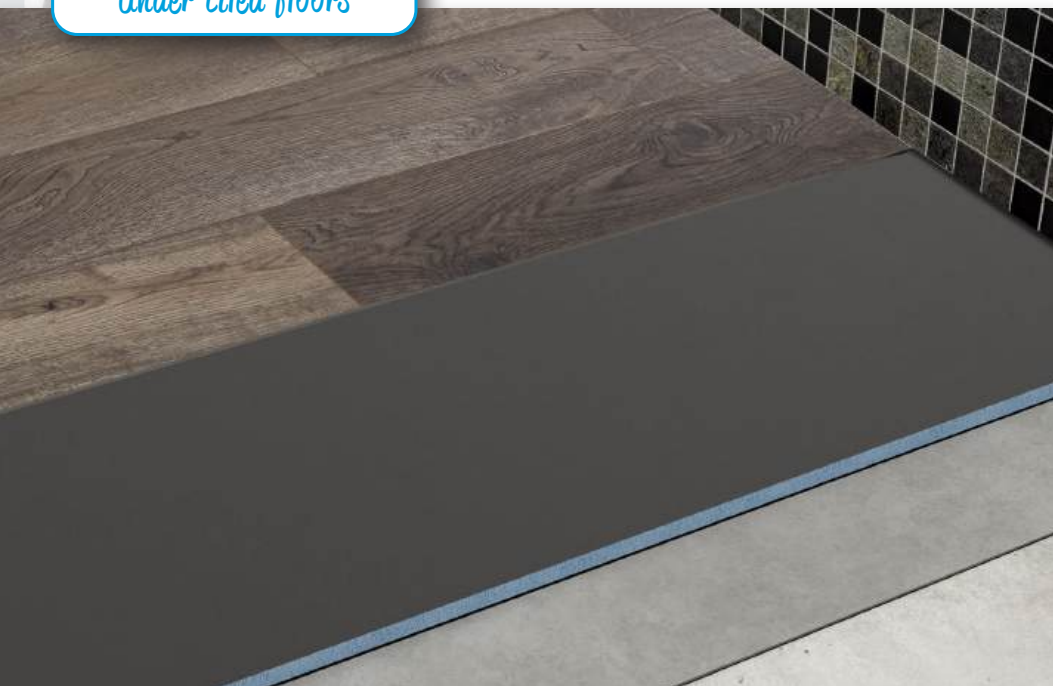

Key Benefits

- 8mm or 12mm
- Reduce impact noise
- Use either side up
- Fully Waterproof

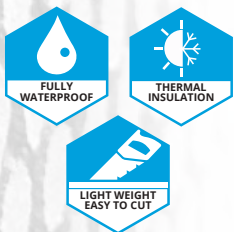

Sound Multiboards are like standard Multiboards but with a layer of rubber foam. They offer 2 applications for reducing impact noise on floors.

Under Tiles

When used under tiles, Sound Multiboards help to eliminate any echo or hollow sound from footfall on the floor.

Under Laminate

An ideal way to add waterproof protection and thermal insulation under laminate flooring.

Sizes & Quantities

Description	Size (mm)			Quantity per pack
	Thickness	Width	Length	
Sound Multiboard	8, 12	1200	600	6

Sound Multiboards

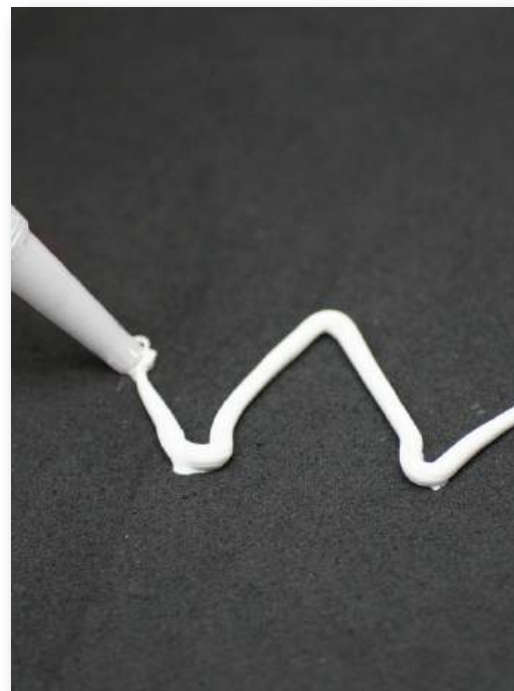
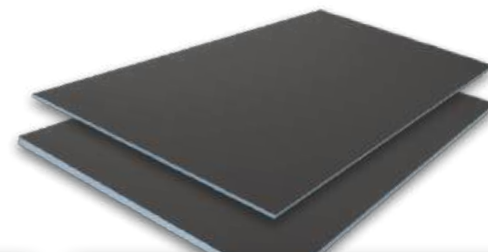

Fitting Instructions

For Tiles

1. Fix (rubber-side down) to the floor using flexible tile adhesive or Marmox MSP360.
2. Leave a 4mm gap between the edge of the boards and the wall.
3. Next, fill the 4mm gap with MSP360.
4. Waterproof joints with Marmox S/A Waterproof Tape.

For Laminate

1. Fix the concrete honeycomb face to the floor using a flexible tile adhesive.
2. With the rubber side up, lay the laminate down as per laminate instructions.

Note

- *The rubber compound is natural so there is no plasticiser migration ensuring the material neither shrinks, degrades or becomes brittle.*



**Marmox S/A
 Waterproof
 Tape**



**Marmox
 MSP360**

Sloping Floors
Wetrooms or balconies

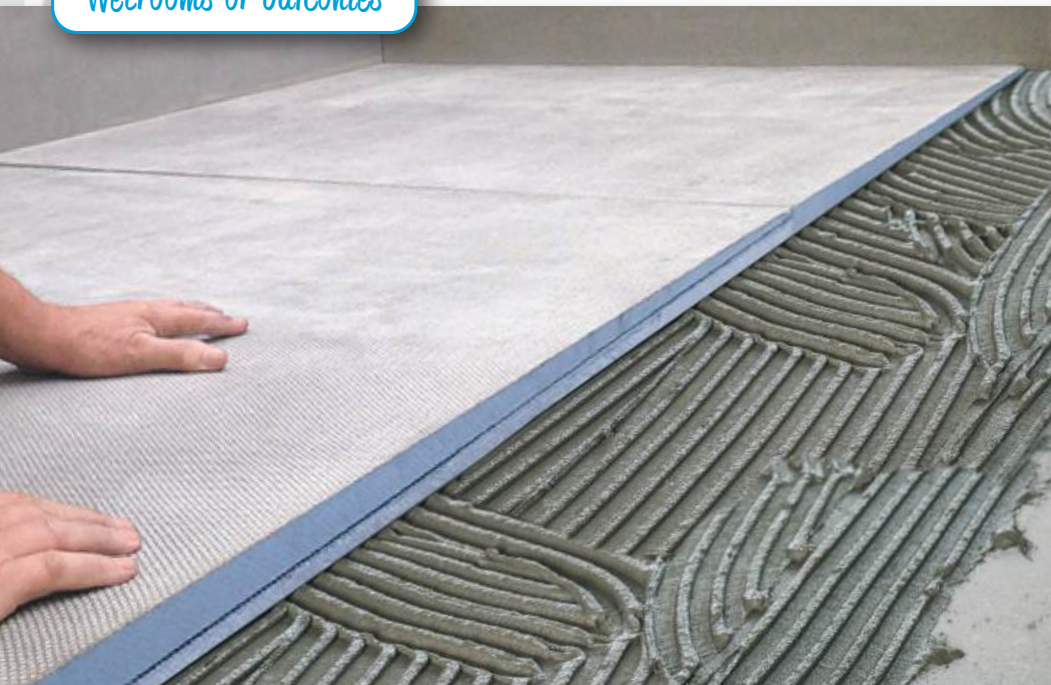

Key Benefits

- 33mm slope to 10mm
- Slope to drain channel
- Easy to cut
- Can be stacked

Slope the entire floor to a channel drain with Marmox Sloping Multiboard.

Ideal for communal shower areas, balconies, external walkways or flat roofs! Sloping Multiboards have a built in slope from 3mm down to 10mm. Each sheet is 1200x1200mm and they can be butted together or stacked to elongate the slope.

Sizes & Quantities

Description	Size (mm)			Quantity per pack
	Thickness	Width	Length	
Sloping Multiboard	33→10	1200	1200	2

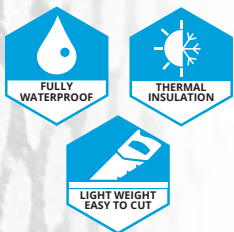

Sloping Multiboards



Fitting Instructions

1. For use on a level flat level surface.
2. Comb a full bed of powder based tile adhesive over the surface of the Sloping Multiboard or onto the floor. 6/8mm trowel (20mm trowel for uneven floors)
3. Push firmly onto the floor.
4. Sit the Sloping Multiboard side by side with the thin edge closest to the wall or butted up to where the drain will be.
5. To extend the area out further, lay down standard 20mm Multiboard and then sit another Sloping Multiboard on top.
6. Waterproof joints with Marmox S/A Waterproof Tape.

Note

- A continuous slope can be created when used in conjunction with 20mm Multiboards.
- Use for wetrooms, balconies and even flat roofs



Marmox S/A
 Waterproof
 Tape



Marmox
 MSP360

Construction
Many possibilities



Key Benefits

- Lightweight
- Very Strong
- Easy to cut
- Many uses

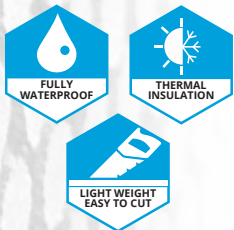

Marmox Multiboards are extremely versatile and can be used for many construction tasks.

High strength, lightweight, easy to cut and available in thickness's up to 60mm, Marmox Multiboards can offer a solution to a whole range of projects.

Vanity units, bath surround steps, shelving! Use long 50-60mm Multiboards for wall partitions, which can be fitted with Marmox brackets. Or use them to block up unwanted door or window openings.

Of course, the uses for Marmox Multiboards doesn't stop in the bathroom, you can also use them externally! Build garden furniture, partitions and even plant pots and surrounds.

Thicker Multiboards



Fitting Instructions

1. Cut Multiboards to size with a saw or knife.
2. There are a range of different fixings available to secure the Multiboards, including Marmox brackets, corkscrew fixings, fixing dowels or screws and metal or plastic washers.
3. Alternatively, use Marmox MSP360 Adhesive and Sealant.
4. If you are going to render or plaster your creation, then tape all the joints with Marmox Reinforcing Tape.
5. If not plastering or rendering then you can waterproof the joints with Marmox S/A Waterproof Tape.
6. You can then tile, plaster or render.

Note

- *With a little creativity, when it comes to uses for Multiboards, the sky really is the limit.*



Corkscrew Fixing

Marmox MSP360

Stylish Curves
Flexible Multiboards



Key Benefits

- Curve to shape
- Easy to install
- Ideal for wet areas
- Use for construction

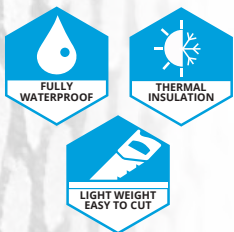

Create Stylish Curves for walls, baths or vanity units!

Marmox Curved Multiboards are extremely versatile and are the ideal solution to fully waterproof a bathroom or wetroom. They offer limitless design possibilities to create curved walls, curved partition walls and curved bathroom panels.

A radius as tight as 200mm can be achieved.

Sizes & Quantities				
Description	Size (mm)			Quantity per pack
	Thickness	Width	Length	
Curved Multiboard	20	600	1200	5

Curved Multiboards



Fitting Instructions

1. Curved Multiboards come flat packed and can be easily bent to the required radius.
2. Ideally the best way to bend the curved Multiboard is to have the slits on the inside of the circular shape at all times and the smooth edge on the outside.
3. Fix to either a curved masonry surface with a continuous bed of flexible tile adhesive or to a wooden or metal frame with its studs at 300mm centres using 5 screws and washers per stud (15 fixings per board).
4. Tape joints with Marmox Reinforcing Tape or Marmox S/A Waterproof Tape.
5. Tiling can now begin.

Note

- You can also bend the curved Multiboard with the slits on the outside. If this is done then a flexible cement based tile adhesive needs to be used to fill out all of the slits on the surface and a sheet of Marmox fibreglass mesh needs to be layed over.



Cover Pipework
Just fold & stick

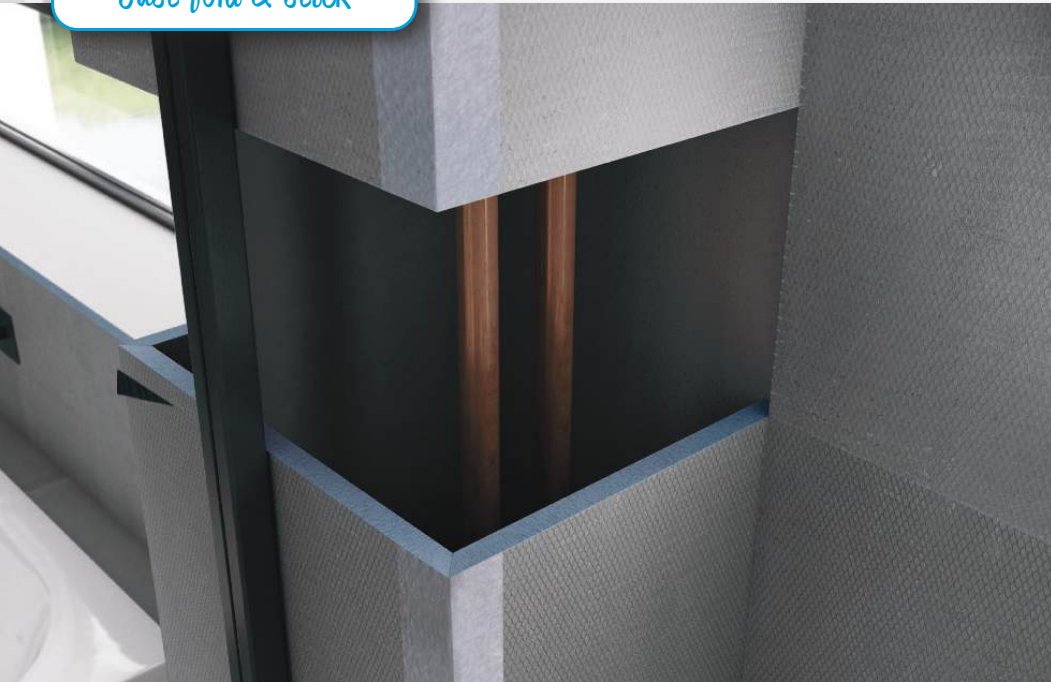

Key Benefits

- Fold and stick at 90°
- Easily cover pipework
- Ideal for wet areas
- No timber needed

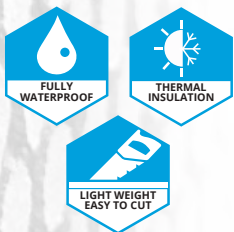

Tidy up unsightly Pipework!

Simplify the process of concealing pipes with the straightforward installation of Marmox pipe boxing. No more need for time consuming and costly timber frames, just cut to the length required, fold and stick in place.

Sizes & Quantities				
Description	Size (mm)			Quantity per pack
	Thickness	Width	Length	
Multiboard Pipe Boxing	20	150 x 150	1200	10
		200 x 200		5
		300 x 300		
		400 x 200		

Pipe Boxing Multiboards



Fitting Instructions

1. Measure pipe work to ensure the correct size pipe boxing.
2. Cut the pipe boxing to the required size.
3. Peel off the backing tape from the self-adhesive strip and fold the board to a 90° angle.
4. Use x4 Marmox wall brackets per 1250mm board.
5. Run a bead of Marmox MSP360 Adhesive & Sealant along the edges of the pipe boxing and offer it up to the wall.
6. Secure the wall brackets with screws.
7. Be sure to tape all the joints with Marmox Reinforcing Tape or Marmox Self Adhesive Waterproof tape.

Note

- *Multiboard pipe boxing can be stacked up to the necessary height, just put a bead of Marmox MSP360 where the Multiboard meets.*



Inbuilt Shelves
Pre-formed ready to tile



Key Benefits

- Stylish & convenient
- Easy to install
- Ideal for wet areas
- Many sizes available

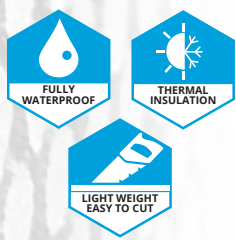

Create easy recessed shelving.

Multiboard Niche are pre-formed and ready to tile. The 800 x 400mm has an adjustable shelf that can be fixed into the desired position.

Sizes & Weights					
Description	Multiboard Thickness	Size (mm)			Weight (kg)
		Width	Length	Depth	
Multiboard Niche	12.5	400	200	100	1.5
			300		2.0
			400		2.5
			500		3.0
			800		5.0
			1200		8.0
		600	300	100	3.0
Corkscrew	-	41	108	-	-

For Technical Data sheet: www.marmox.co.uk/niche

Multiboard Niche



Fitting Instructions

Shelf version only

1. Slide the shelf into the desired position (If applicable).
2. Use a pencil and mark a straight line to indicate the final shelf position.
3. Screw Corkscrew fixing through the sides of the niche, into the shelf, ensuring to screw in well but do not over tighten.

All versions

4. Position the niche between the studwork.
5. Use a minimum of a 50mm screw and a large washer in all of the corners.
6. For further waterproofing use 'Marmox MSP360 Adhesive & Sealant' or 'Marmox S/A Waterproof Tape'.

Other sizes (mm) (without shelf)



Tileable Basin
 Push Plug or Linear

Infinity Style

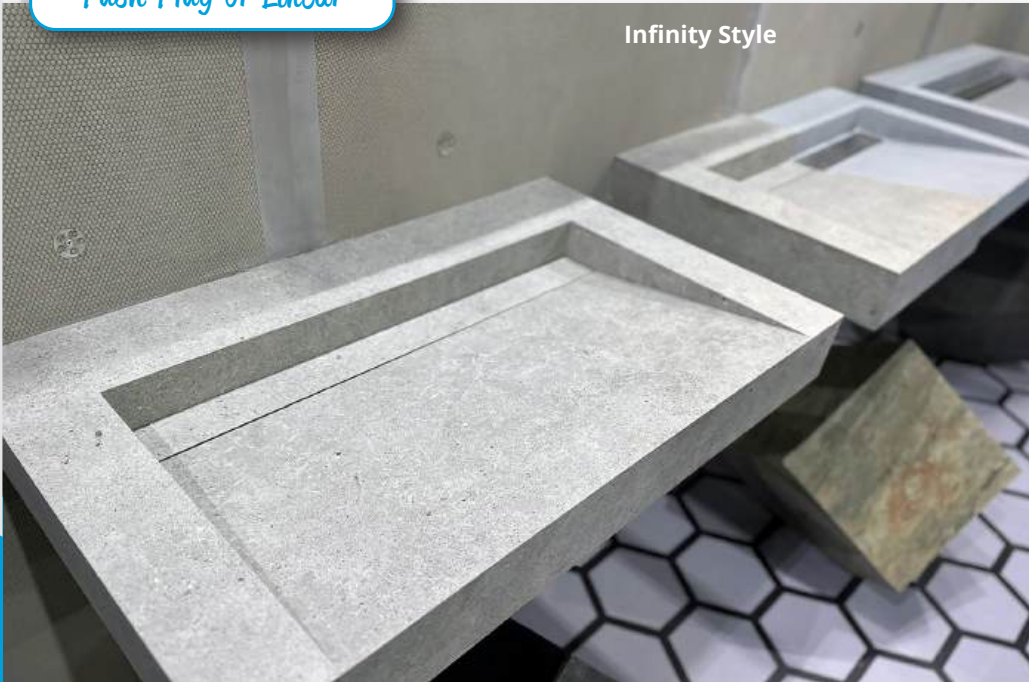

Key Benefits

- Tileable & Waterproof
- Linear or Point Drain
- Hangs on Wall
- Internal Support

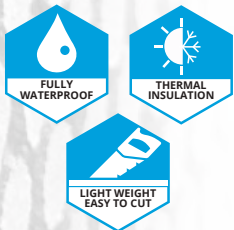

Stylish wash basins with your own tiles!

Create a seamless, modern finish in any bathroom with Marmox Tileable Wash Basins. Designed to be tiled directly, they remove the need for costly custom units. Simply fit the basin, apply your chosen tiles and achieve a completely personalised look. Strong, waterproof and easy to install, they provide a practical base for unique bathroom designs. Shelf can be used as an extension

Sizes & Quantities

Description	Size (mm)		
	Height	Width	Length
Infinity - Hidden Drain	100	770	485
Linear			
Push Plug			
Shelf			



Infinity (No visible drain once tiled)



Linear



Push Plug



Shelf

Fitting Instructions

Multiboard basins are fitted to solid walls using the internal support bars. These are fixed to the wall using the wall fixings provided with the basins. The internal bars are then secured using Marmox MSP360.

For full fitting instructions visit www.marmox.co.uk

Note

- *The Shelf can be used on it's own as a tileable shelf or used as an extension piece for the basins when butted up against it.*



Bottle Trap Black



Bottle Trap Chrome



Push Plug



Marmox MSP360

Tileable Bath
Stylish and waterproof



Key Benefits

- Ready to tile
- Waterproof
- Side & end panel
- Adjustable feet

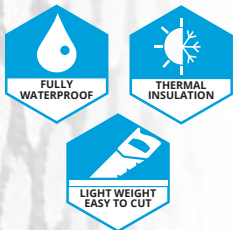

Finished coating your walls and floors? Why stop there?

Marmox Multiboard bath panel kits offer a simple installation for a stylish tiled bath surround. This handy kit includes side and end panels, adjustable feet and Marmox Self Adhesive Waterproof Tape. Tile directly onto the Multiboards!

Sizes & Quantities				
Description	Size (mm)			Quantity
	Thickness	Width	Length	
Side Panel	30	600	1800	1
End Panel	30	600	800	1
Adjustable Feet	4	-	-	4
S/A Waterproof Tape	1	100	10(m)	1

Bath Panel Kit



Fitting Instructions

1. Ensure your bath has a sufficiently wide recess under the lip of at least 30mm, to fit the panel under the edges.
2. Measure the end of the bath and cut the end panel to size. (Make sure to leave a 30mm gap on outer edge for the side panel to sit in front of).
3. Wedge panel under the end of the bath.
4. In the same way, cut to size and apply the side panel.
5. Tighten the adjustable feet.
6. Apply the Marmox S/A Waterproof Tape where the 2 panels meet each other and where they meet the wall.
7. Ready to tile. Tile directly onto the Multiboard.

Note

- *Our NEW 1200 x 400 niche is the perfect addition along your bath wall. (See p23)*



Marmox S/A Waterproof Tape

Bath Panel Feet

Tileable Slope
Pre-formed falls



NEW Easy Access Point Drain

Key Benefits

- Pre-formed fall ready to receive tiles
- Lightweight
- Quick & easy to install
- Lifetime guarantee

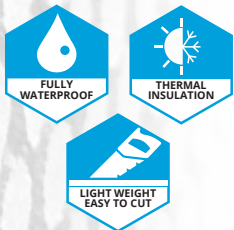

Showerlays provide a ready-formed slope that directs water efficiently towards the drain, allowing the creation of a fully tiled, level access shower area.

By removing the need for on-site screeding and forming accurate falls, Showerlays simplify installation and deliver a consistent and dependable gradient and recent updates include a fleece for easy waterproofing around the perimeter.

New sizes and drain positions are now available, allowing them to suit a wide selection of wetroom layouts.

Showerlays can be trimmed on all sides by up to 100mm and when used in conjunction with Marmox Multiboards on surrounding walls and floors, they create a complete, waterproof shower area ready for tiling.

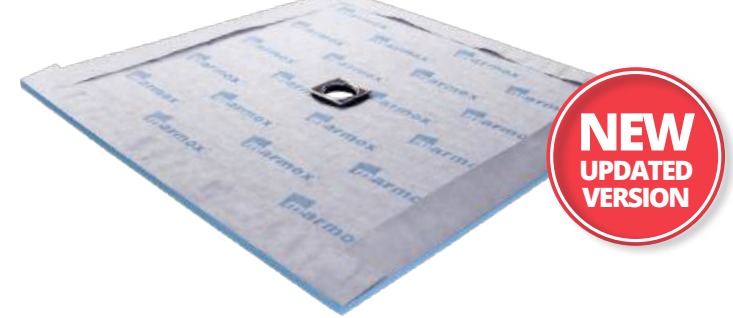

Centre Drain Position

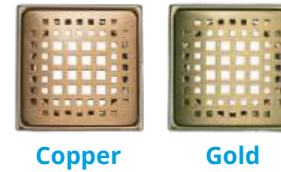
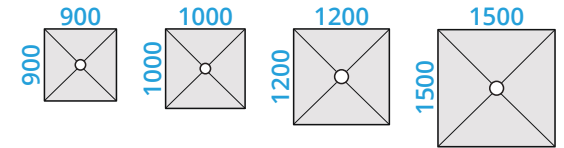

Copper Gold



White Black



Stainless Steel

Offset Drain Position (mm)
 (all offset by 320)

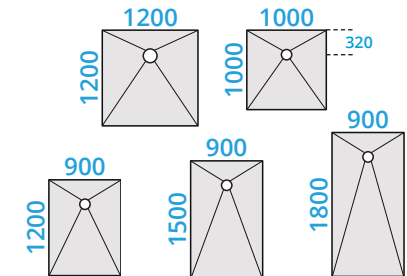

Fitting Instructions

Multiboard Showerlays can be laid on wooden or concrete floors using a Marmox MSP360 or a good quality tile adhesive.

For concrete floors, we do offer the option of an XPS plinth in which the drain and pipework can be cut into.

For full fitting instructions visit www.marmox.co.uk

Note

- Each Showerlay comes complete with a drain and drain grate. Be sure to select your desired grate colour when you order.



Tileable Slope
Pre-formed falls



Key Benefits

- Pre-formed fall ready to receive tiles
- Lightweight
- Quick & easy to install
- Lifetime guarantee

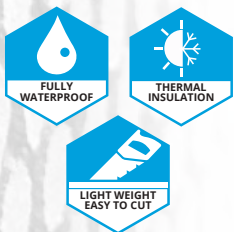

Showers for linear drains feature a factory-formed fall that channels water cleanly along the length of the drain, enabling a tiled, level access shower finish.

Eliminating site screeds and guesswork, they speed installation while providing a reliable, uniform gradient, with a perimeter fleece to simplify waterproofing.

Extended formats and varied drain locations support many wetroom designs, making them suitable for residential or commercial use.

Each Showerlay may be trimmed by up to 100mm on every edge and, combined with Marmox Multiboards to walls and floors, forms a fully waterproof shower area prepared for tiling.

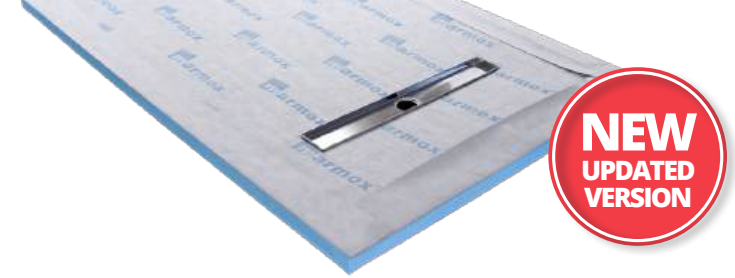

Tileable



Copper



Gold



White



Black



Dashed

Linear Drain Position (mm)
 (all offset by 335)

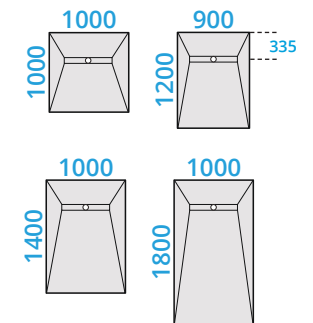

Fitting Instructions

Multiboard Showerlays can be installed onto both timber and concrete floors using Marmox MSP360 or a suitable high-quality tile adhesive, providing a stable and secure base.

Each Showerlay can be trimmed by up to 100mm from any side to allow accurate fitting on site.

For concrete floors, an optional XPS plinth is available, enabling the drain and pipework to be recessed neatly below floor level.

For full fitting instructions visit www.marmox.co.uk

Note

- Each Showerlay comes complete with a drain and drain grate. Be sure to select your desired grate colour when you order.



Marmox S/A
 Waterproof
 Tape

Marmox
 MSP360

Accessories

Marmox MSP360:

Premium Adhesive and Sealant. Ultra high performance, professional, heavy duty. Fully waterproof - it even cures under water!



Marmox Waterproof Fleece:

Fully waterproof fleece for tanking wet areas. For use with or without Multiboard



Fixings: A range of fixings including: Self Drilling Screws, Countersunk Head Hammer-In Fixings, Metal Insulation Fixings



Marmox S/A Waterproof Tape:

10 metre roll of the popular Marmox tanking tape for use with Marmox Multiboards in all wet areas.

Marmox Reinforcing Tape:

Use over joints before plastering. 50mm or 100mm



Corkscrew fixings:

Use in construction projects to secure Multiboards together.



Marmox Washers: Available in buckets (500) or bags (100), in metal or plastic. **Note:** plastic washers only available by the bag.



Other Marmox Products



Marmox Thermoblock: Designed to replace a layer of bricks or blocks within the structure, helping to eliminate thermal bridging at critical junctions, particularly where the floor meets the wall. By interrupting the direct path for heat loss, it supports improved thermal performance at ground level. Available in a range of sizes and thicknesses.



Marmox Fireboard: A1 rated stone wool insulation boards suitable for both internal and external applications. Designed to provide effective fire protection while also contributing to sound insulation, helping to reduce the transmission of noise through walls, floors, and ceilings.

Available in 12mm, 20mm, 50mm & 100mm thicknesses.

Marmox MSP360-Fire: Adhesive/Sealant with up to 3hrs fire protection

For our full range of products visit: www.marmox.co.uk

Always look out for the honeycomb finish

*It means... Genuine Marmox and an
ultra-strong surface for adhesion!*

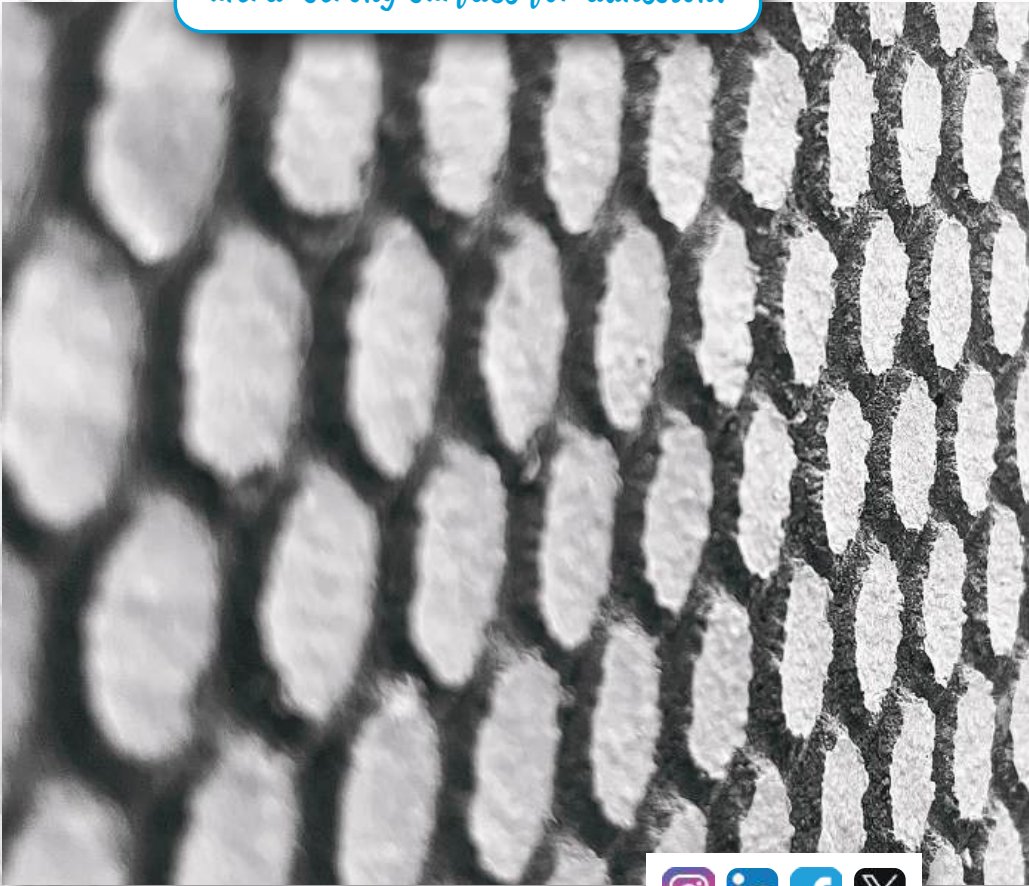

Marmox UK Ltd

Caxton House,
101-103 Hopewell Drive,
Chatham, Kent. ME5 7NP
United Kingdom

For information and advice:

Tel: 01634 835290
Email: sales@marmox.co.uk
Web: www.marmox.co.uk

marmox
Waterproofing & Insulation Solutions